

CONCORE Multi-Angle sawing machine

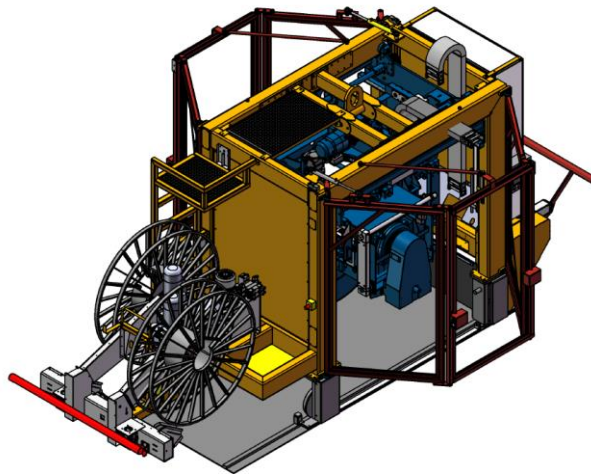



The Concore Multi-angle sawing machine for slabs with heights up to 550 mm and width up to 1.200 mm. The design of the sawing machine combines a rigid mechanical construction with stable and sophisticated automation into functioning combination. The sawing machine runs in manual or automatic mode. Pre-programmed saw settings can be set for different profiles, special programs for automatic double cut of high slabs are built into the control system. The control system will give keep track of all historical data from the machine usage. All speeds are adjustable. Angles between 0-180 degrees and longitudinal splitting of slabs. The machine is easy to use, service and maintain. Position of the sawing blade is projected onto the slab by a laser line.

Optional: fully automatic drive. The saw can be driven in full automatic mode where all cutting will be carried out exactly the same as shown in the drawing. System for the positioning is the same as in the Concore Plotter and Polystyrene cutter.

- Optional fully automatic sawing
- Optional Blade cover
- Optional Safety grid
- All speeds step are adjustable
- Automatic double cut programs build into the saw machine
- Electric driven power cable drum
- Electric driven water hose drum
- Continues speed control for blade motor 55 kW
- Remote support online

Technical details:

Blades diameter	800-1300 mm
Cutting speed	max. 3,8 m/min
Movement speed	max. 35 m/min
Power supply	3 P + PE 400 V 50/60 Hz, main fuses 3x125 A
Weight	7300,00 kg

